

QUARTECH

LT450/455 W SERIES OF CERAMIC FILTER

ELECTRIC CHARAC

Part Number	Centre Frequency (F ₀ ±KHz)	Insertion Loss (dB)	Pass Band Ripple (dB)max.	6dB Band Width (KHz)min.	50dB Band Width (KHz)min.	Stop Band ±100KHz (dB)min.	Input/ Output Impedance (ohms)
LT450/455AW	±2.0	4	2	±17.5	±35	40	1000
LT450/455BW	±2.0	4	2	±15	±30	40	1500
LT450/455CW	±2.0	4	2	±12.5	±24	40	1500
LT450/455DW	±1.5	6	2	±10	±20	40	1500
LT450/455EW	±1.5	6	2	±7.5	±15	40	1500
LT450/455FW	±1.5	6	2	±6	±12.5	40	2000
LT450/455GW	±1.5	6	2	±4.5	±10	40	2000
LT450/455HW	±1.0	6	2	±3	±9	40	2000
LT450/455IW	±1.0	6	2	±2	±7.5	40	2000
LT450/455HTW	±1.0	6	2	±3	±9	60	2000

DIMENSIONS (mm)

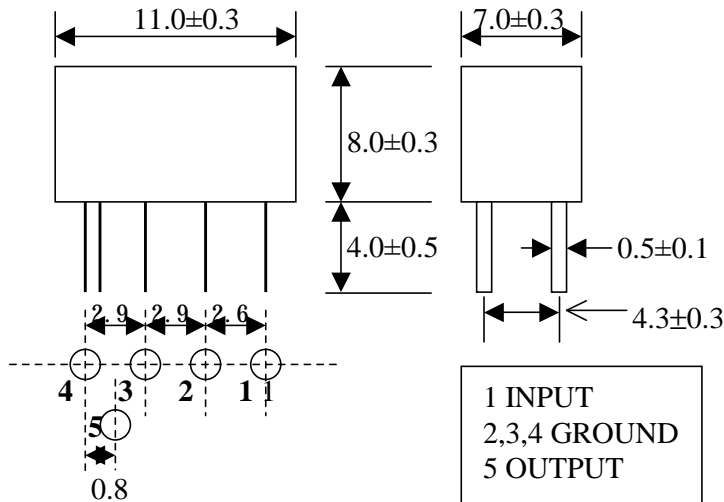

Test Circuit

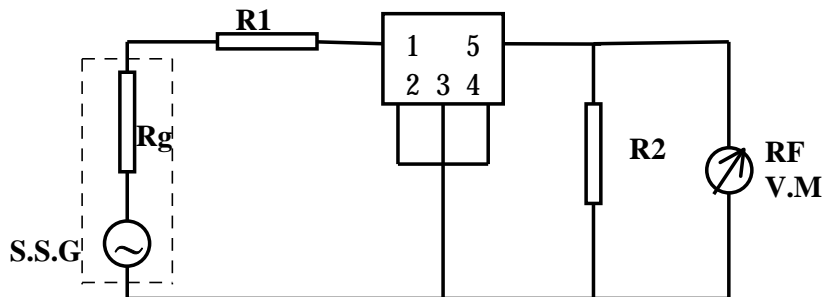

$$R_g + R_1 = R_2 = \text{Input/Output Impedance}$$